

Profile Series Solo 1-Tank Monitoring & Display Panels and Under Counter Display Modules

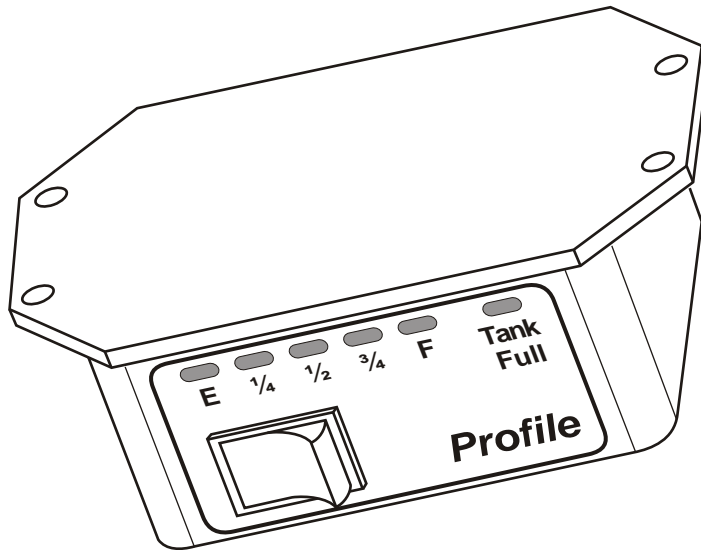
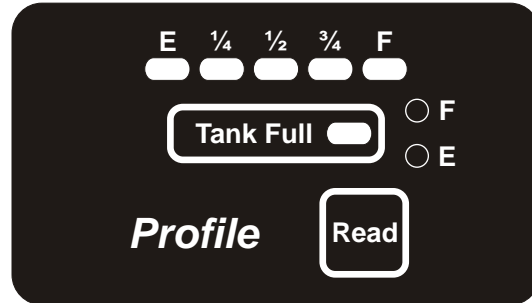
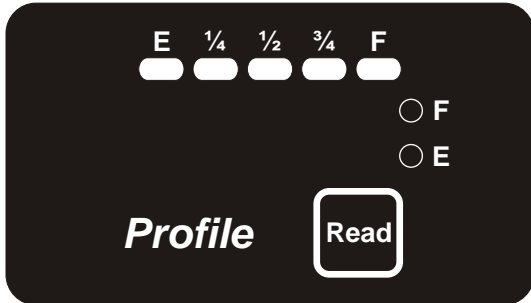

New Providence Marine Systems

Copyright © 2007

PROFILE SERIES

Table of Contents

Topic	Page
1:Introduction	2
2:Installation Guide	3
3:Monitor Software Configuration	8
4:System Calibration	9
5:Troubleshooting	10
6:Limited Warranty	12
7:Product Registration Form	13

Introduction

Have you ever been disappointed with the accuracy of a tank monitor? We have overcome the accuracy problem with tank and sensor profiling with EZ-Profile. What is EZ-Profile? EZ-Profile is our exclusive software algorithm developed specifically for our Profile series of monitoring panels. It significantly improves the accuracy of the displayed data by correcting for sensor type and oddly shaped tanks so common in the marine industry.

Our Profile series Solo display panels and under counter modules are compatible with our own line of non-contact level sensors, non-contact sensors manufactured by several other companies, and even standard 240-33 Ohm float level sensors.

Some variants of the Profile Solo units will also autonomously monitor the attached tank and alert you with a red warning light when the tank level is approximately 80% of calibrated capacity.

We have taken considerable time and effort to ensure that you have purchased the best marine tank monitoring system possible. Our Engineering and Sales staff has over five years experience in the Marine Industry and has launched several highly successful marine products. Capitalizing on this experience, we have addressed issues learned over the past five years and incorporated features missing from other systems. However, a quality product does not depend entirely on its design. In order to ensure continuing product quality we build all of our products on our state of the art electronics production line and test and inspect each and every monitoring system several times prior to packaging and shipping to the customer. This design represents our current best effort and is perhaps the best monitoring system available on the market today.

Key Features of The Profile Solo Monitoring Panels and Under-Counter Display Modules

- 1) Monitors a single tank making it ideal to install in the bathroom of your boat.
- 2) Display accuracy and linearity is significantly improved with our exclusive EZ-Profile software algorithm. Basic tank shape and sensor type can both be selected by the user. The EZ-Profile software then corrects the displayed bargraph for non-linearities associated with odd-shaped tanks (common in marine applications) and different sensor types.
- 3) Some variants of the Profile Solo monitoring panels and under-counter display modules will autonomously monitor the attached tank. When the level goes above approximately 80% the red warning light is lit.
- 4) Tank levels are displayed as a 5 position LED graph which is easy to read in low light conditions.
- 5) Compatible with non-contact capacitive level sensors, 33-240 Ohm float-style sensors, and 0-5 volt output sensors which allows maximum flexibility when specifying sensors. This across-the-board sensor compatibility also makes retrofit onto an existing system very simple as it can take advantage of existing sensor and wire installations.

Installation Guide

This monitoring system has been designed to be installed with common tools and materials by both marine professionals and boat owners. The installation process is fairly involved, but can be accomplished as a series of simple steps. We highly recommend you read this manual in its entirety and familiarize yourself with each step prior to beginning the installation. You should also read the owners manuals for each sensor type you are installing and become familiar with them as well. If you have any questions at all about the installation or setup process please contact our technical support staff. They will be happy to answer any questions you have to ensure a successful installation.

Included parts

The standard after-market panel kit contains the monitoring panel and a non-contact sensor (sensor not shown, refer to its owners manual). The under-counter display unit also ships with a non-contact sensor as well as a wiring harness for the display.

Figure 1: Profile Solo monitoring panel and under counter display

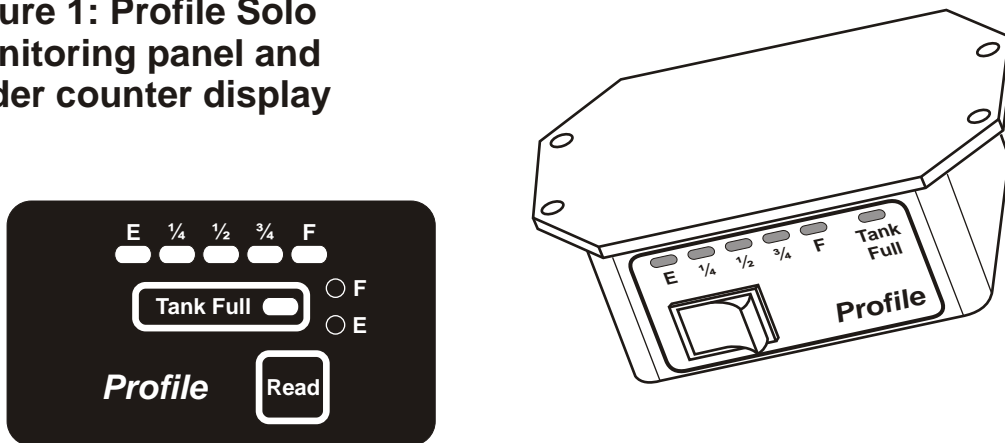

Required additional tools and materials

In addition to the contents of the monitor panel kit and various sensor kits, you will need to provide the following tools and materials to install the monitoring panel in your boat:

- 1) Tape measure
- 2) Pencil and permanent marker
- 3) Electrical and masking tape
- 4) Phillips screw driver
- 5) Keyhole or electric jig-saw appropriate to cut the panel installation hole (if installing the a Solo display panel)
- 6) Wire cutter, stripper and terminal crimper for 18 AWG wire (inexpensive combination tools are usually available at most auto parts or hardware stores)
- 6) Electric drill and drill bits
- 7) 18 AWG stranded wire in 3 colors: red, blue, and black (make sure you have enough wire to pull all three wires from the panel location to each sensor)
- 8) Crimpable insulated butt connectors for 18 AWG wire (you will need at least 7)
- 9) 4 sheet metal screws and thin washers to secure the monitoring panel to your wall or to secure the under counter unit beneath a counter or cabinet(select screws with head colors to match your boat decor)

You may also need additional tools and materials to install the various sensors for your system. Refer to the owners manuals for your sensors for a list of these items.

Installation: Display Installation

The first step in installing the monitoring system is to select an appropriate location for the display panel or under counter module . It should be in a location that is easy to see and access and be protected from weather or spilled fluids. You should also consider the ease with which you can pull the various power and sensor wires from the tank sensors to the proposed monitoring panel location. A good location for the through-wall display panel should also have a minimum of 1inch of clearance for the depth of the display panel electronic circuit board and sensor wiring.

If you are installing a Solo display panel (instead of the under counter module), you will need to cut a rectangular hole in the wall in which to install the monitoring panel and its related wiring. This hole should be 1½ inches tall by 2 3/8 inches wide. Measure this opening carefully with the tape measure and mark the opening with a pencil. Take care to mark the opening so that it is square with the floor and walls of your boat for a good aesthetic appearance. When you are satisfied with the location and opening markings, use your saw to cut the opening as close to the lines you made as possible. Test fit the panel in the opening you just made and clean up or enlarge the hole if necessary so that the monitoring panel will slip in squarely and lay flat against the wall. Holding the panel in place in the opening, use a sharp object to mark the location on the wall of the panels four corner mounting holes. Remove the panel and use your electric drill and an appropriately sized drill bit to drill four pilot holes for the sheet metal screws that will be used to secure the panel. Do not mount the panel yet.

If you are installing a Solo under counter display module (instead of the wall mounted display panel) you will need to drill four pilot holes for the four mounting screws to secure the unit. Hold the display module at the selected mounting location and use a sharp object to mark the center of each of the 4 mounting holes on the 2 flanges on display module. Remove the module and use your electric drill and an appropriately sized drill bit to drill four pilot holes for the screws that will be used to secure the display. Do not mount the mount the display module yet.

Installation: Sensor Installation

You should refer to the owners manuals for specific installation instructions for each sensor type we manufacture. 240-33 Ohm float sensors might already be installed in your tanks as they are quite common. If you are installing new float sensors, refer to documentation and instructions from the sensor manufacturer and take advantage of available adapters or mounting kits to keep their installation as simple as possible.

Installation: System Wiring

Once the pilot holes are drilled and the panel opening is created (if required) and the sensor is installed onto the tank, you can install the wiring which will attach the tank sensor to the display panel and the display panel to your boat's power system. You will use 18 AWG stranded wire for both of these tasks, preferably in three colors: red, blue, and black. Each sensor we manufacture uses a black wire for ground, a red wire for its power supply, and a blue wire for its output. A red and blue wire from the sensor must be pulled from the tank to the display location. You may also pull a black ground wire from the sensor to the panel location and attach it to the panel's ground, or you can attach it to a good low impedance ground near the monitored tank.

If you are attaching 240-33 Ohm float sensor, you only need to pull a single blue sensor wire from the sensor to the display panel; no red power wire is required for this sensor type. You will also need to ground this sensor by pulling a wire back to the panel or attaching the ground wire to a good low impedance ground near to the sensor.

Route all wires so they are well away from potential heat sources (like the oven or exhaust pipes), and away from any moving parts which might damage the wire insulation. Also, do not use staples or nails to secure wiring as these might also cause damage to wire insulation potentially causing short circuits--use nylon ties to secure the wires instead .

Pull the wires from the sensor location either through the hole you created for the panel, or to the under counter module mounting location leaving about a foot of slack on each wire so that it is easy to strip, crimp, and attach to the back of the display. As you pull each wire, take care to mark the ends of each wire with a bit of masking tape on which you write the name of each signal. This will prevent a lot of confusion later on when you terminate and attach each wire to the panel.

Installation: Wire Termination & Hookup

Once all the wire is pulled through the boat, strip about ¼ inch from the ends of the wire on the tank sensor end and butt-connect to the installed sensor: red to red, blue to blue, and black to black. Also strip ¼ inch from the ends of the wire at the monitoring panel. Connect the blue wire from the sensor to the blue wire attached to the panel; connect the red wire from the sensor to the white wire attached to the panel. Next attach the sensors ground wire to the boat's ground either locally at each tank, or all together behind the monitoring panel. Figure 2 shows one of our standard sensors attached to the Solo panel 1; Figure 3 shows the attachment of one of our capacitive sensor rods. These figures depicts the attachment of our 2 most common sensors but applies to other sensor types we manufacture as well.

If you are attaching a 33-240 Ohm float-style sensor, you will need to modify the Solo monitoring panel or under counter display slightly per the following:

If you are installing a through-wall display panel, first remove the circuit board carefully from the aluminum face plate by removing the 4 corner nuts. You will see a shorting jumper on the circuit board in between the red and black wires; remove it and re-install it so that covers both bare pins (when the panel is manufactured this shorting jumper is only covering one pin) then re-attach the circuit board to the face plate. Attach one wire from the 33-240 Ohm float sensor to the blue wire of the monitoring panel and connect the other wire on the float sensor to ground. Do not attach anything to the white wire on the back of the monitoring panel--insulate its loose end with some electrical tape to prevent it from shorting out. Figure 4 in this section shows a float sensor attached to a monitoring panel.

If you are installing an under counter display, first remove the 4 corner screws securing the enclosure lid and remove the lid to expose the circuit board. Near the center of the circuit board you will see a shorting jumper on a single pin; remove it and re-install it so that it covers both bare pins. Take a moment to identify the "Full" and "Empty" calibration buttons near the edge of the circuit board; you will use these buttons when you are ready to set tank shape, sensor type, and to calibrate the unit for empty and full. For now leave the enclosure lid off. Attach one wire from the 33-240 Ohm float sensor to the blue wire of the monitoring panel and connect the other wire on the float sensor to ground. Do not attach anything to the white wire on the back of the monitoring panel--in fact, it can be complete cut off at the wiring harness plug.. Figure 4 in this section shows a float sensor attached to a monitoring panel, while the under counter unit looks different from the display pictured in Figure 4, the wire colors and hookup connections are identical.

Once the sensor is connected to the display, it is time to attach the display itself to a source of 12V power. Attach the monitors red wire to a source of 12V power then connect the black wire to a good low-impedance ground.

Final Installation

If you are installing a through-wall display panel secure the panel into the hole you made in the wall. Initially, use only two screws to hold it in place in case you need to make any changes in the wiring. Do not over tighten these screws as you will damage the Lexan face graphic causing it to wrinkle at the corners. We recommend the use of a very thin washer under the screw head to prevent damaging the face. Once you finish testing and calibrating the system (described in the following sections) and everything works well, secure the panel in place permanently with all four corner screws.

If you are installing an under counter display do not mount it yet for easier access to the setup buttons found inside of the unit. Remove the 4 corner screws securing the enclosures lid and remove the lid and locate the "Full" and "Empty" buttons which you will use to configure the display later. Once you have finished setting up, calibrating, and testing the system (described in the following sections) and everything works well, replace the lid and screw it back down then secure the display under the counter or cabinet where you drilled the mounting pilot holes with 4 screws.

Profile Solo monitoring panel/Red wire from panel to power source, Blk to Ground.

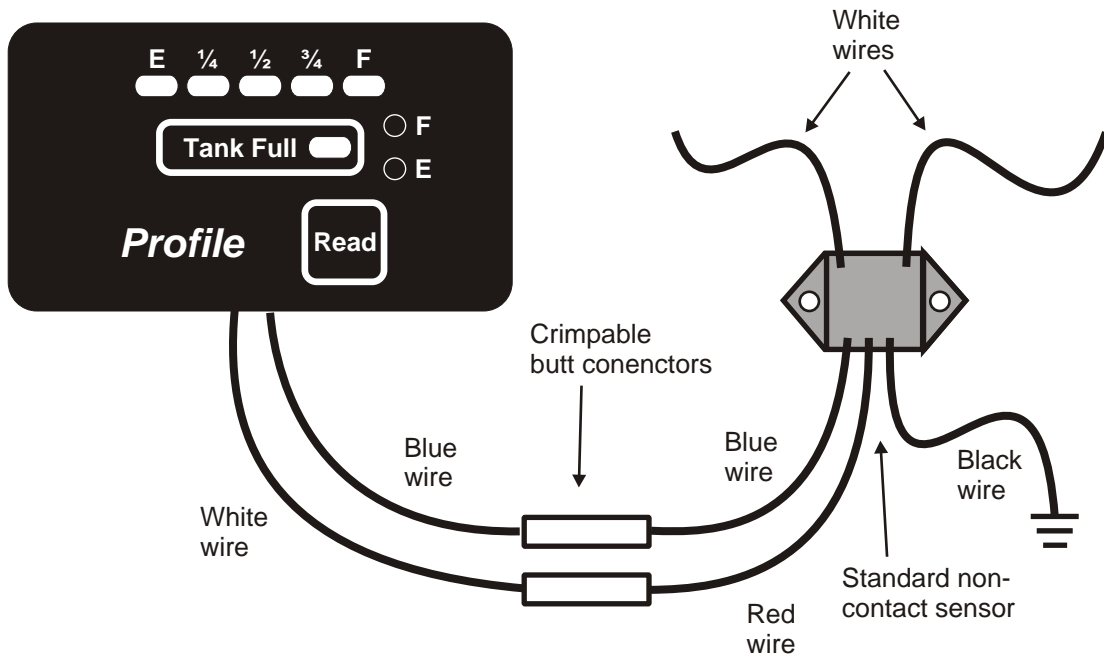

Figure 2: Panel attachment to a standard sensor.

Profile Solo monitoring panel/ Red wire from panel to power source, Blk to Ground.

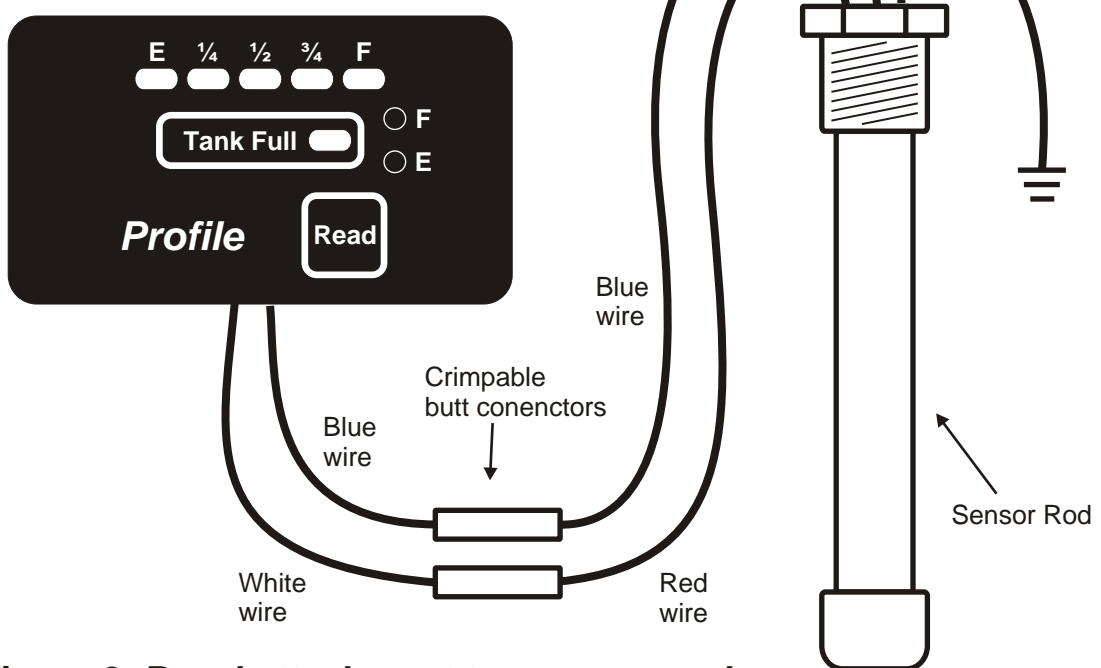

Figure 3: Panel attachment to a sensor rod.

Profile Solo monitoring panel/Red wire from panel to power source/Blk to Ground.

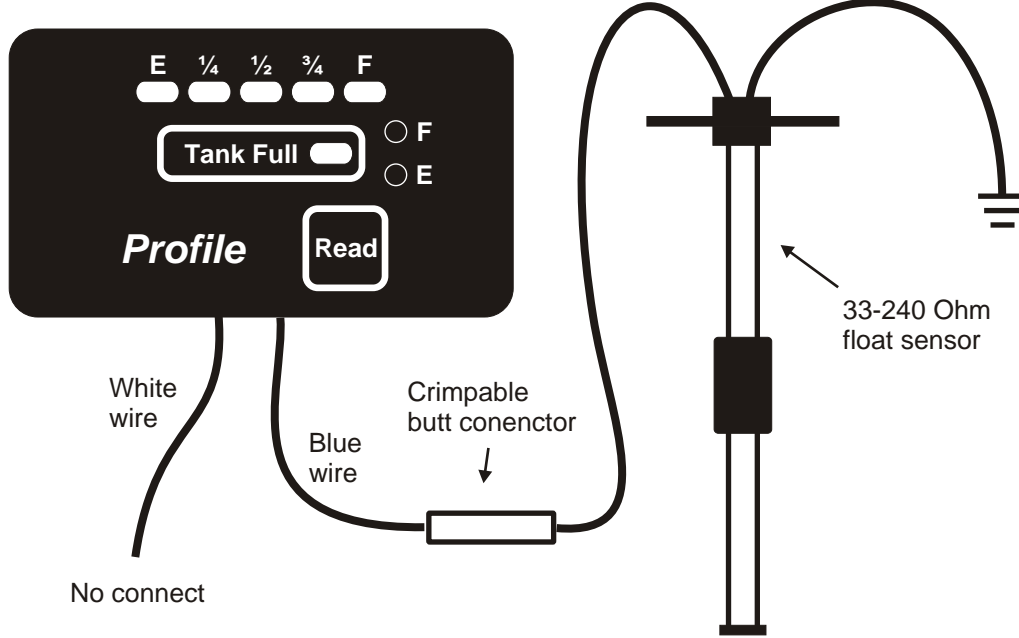

Figure 4: Panel attachment to a float sensor.

Monitor Software Setup

After the panel installation is complete per the instructions in the previous section, it is time to set the sensor type and basic tank shape.

First press and hold down the "Read" button, you should see some lights light up. Next release the button and the lights will go out. For 5 seconds after the lights go back out you can press either of the "E" or "F" buttons to set the sensor type and tank shape. The "E" and "F" buttons are located on the face of the through wall display panel, or inside of the under counter display unit (you will need to remove the enclosure lid on the under counter display to expose the buttons).

Sensor type is set using the "E" button. When you press and release the "Read" button then press the "E" button you will note that one of the lights will come on. Repeatedly pressing the "E" button causes the light to advance one position to the right. Each position corresponds to a different sensor type: the Empty light indicates an external foil sensor, the $\frac{1}{4}$ light indicates a solid state rod-style sensor (note: not a float sensor), the $\frac{1}{2}$ light is for a 0-5V linear output sensor, and $\frac{3}{4}$ indicates a 33-240Ohm float sensor. Press the "E" button several times until the light is lit that corresponds to your sensor then release the button and wait about 5 seconds till the light goes out. The display is now setup for the sensor you selected.

Tank shape is set using the "F" button. Use the identical procedure outlined above to select your tank shape by pressing the "F" button instead of the "E" button. Each light position corresponds to a different tank shape: the Empty light indicates square tank, the $\frac{1}{4}$ light indicates a tank with a tapered cross-section, the $\frac{1}{2}$ light is for a tank with a more exaggerated taper, and $\frac{3}{4}$ indicates a tank with a circular cross-section. Press the "F" button several times until the light is lit that corresponds to your tank shape then release the button and wait about 5 seconds till the light goes out. The panel is now setup for your selected tank shape. We recommend starting out with the square cross-sectioned tank profile first; if the accuracy is insufficient try either of the tapered shapes.

Sensor Channel Empty/Full Calibration

Once the display is installed and the panel software is configured, it will need to be calibrated for empty and full tank conditions.

Empty Calibration

What exactly is an empty tank? The answer to this question might not be as obvious as it sounds. In many cases an empty tank might not be completely empty as it is common in marine applications for some fluid to drain back into a waste tank after pump out. We recommend that you calibrate the empty point to a "pumped out empty" level in which you pump out a waste tank then wait until the outlet plumbing has had enough time to completely drain back into the tank. This way, when you set the empty calibration point of the tank, you are actually setting it to empty point of the true usable volume of the tank.

The attached tank in your system will need its empty calibration point set. As it is pumped out (waste tanks) or is drained through normal usage (fresh tanks), calibrate its empty point by pressing and holding the "Read" button to display the lights, then press and hold the "E" button for at least 4 seconds (you may note a difference in the display once the point is set). This empty point is now stored permanently in the monitors memory and will not need to be reset when power is turned off. MAKE SURE YOU HOLD READ AND E AT THE SAME TIME.

Full Calibration

The tank attached to your monitor will also require a calibration point set when it is full. A good time to calibrate a waste tank is just before pumpout, and a good time for a fresh or fuel tank is just after fillup. To set the full calibration point, press and hold the "Read" button to display the lights, then press and hold the "F" button for at least 4 seconds (you may note a difference in the display once the point is set). This full point is now stored permanently in the monitors memory and will not need to be reset when power is turned off. MAKE SURE YOU HOLD THE READ AND F AT SAME TIME.

Error Checking

The calibration software has some error checking capabilities. If after you set a calibration point you see the ½ light blinking, it means that a full point is being set which is equal to or less than the empty point, or an empty point which is equal to or greater than the full point. When this error occurs, the calibration routine sets default empty and full values. This return to default values clears possible bad calibration data which might make the sensor channel difficult to properly calibrate (i.e. an empty calibration value erroneously set with a full tank would otherwise prevent the setting of a proper full value until the empty point is set back to an appropriate empty value). If you continue to see this error after re-attempting calibration and re-checking the tank level, you may actually be experiencing a problem with the wiring between the sensor and panel (i.e. a disconnected power, sensor return, or ground wire to the sensor) or a bad sensor. If you suspect this may be the case, check the troubleshooting section in this manual.

Problem:

An incorrect calibration value is entered inadvertently on a sensor channel that is otherwise working normally (i.e. an empty calibration value is set too high or a full value is set too low).

Test/Remedy:

If practical, drain the tank and set the empty calibration point then fill it and set the full.

If it is impractical to drain the tank and re-fill (i.e. a fuel tank), then the factory default calibration values for the troublesome sensor channel can be re-set by creating a calibration error.

By intentionally creating a calibration error, you can force the firmware in this display panel to store default calibration values for both empty and full in its memory. These values correspond to a sensor output of 0VDC (zero) for empty and 5VDC for full. These values are identical to the initial values programmed into the display panel when it was first tested at the factory. This return to default values clears possible bad calibration data which might make the sensor channel difficult to properly calibrate (i.e. an empty calibration value erroneously set with a full tank would otherwise prevent the setting of a proper full value until the empty point is set back to an appropriate empty value).

Creating this error can be done by simply setting the full calibration value then immediately setting the empty calibration value (see calibration procedure elsewhere in this manual). By doing this, you are trying to set identical empty and full values that the display panel firmware will not allow, and you should see the ½ light blinking indicating the error. Once the error is displayed, the factory default calibration values for that sensor channel are set.

The return to default calibration values will be reasonably accurate for most sensors, but for maximum accuracy, empty and full calibration for the tank should be done when it is practical to do so.

Limited Warranty

New Providence Marine Systems (New Providence) warrants to the original purchaser that this product is free of defects in materials or workmanship for a period of one year from the product's date of purchase. Should this product prove defective by reason of improper workmanship and/or materials within the warranty period, New Providence shall, at its sole option, repair or replace the product.

1. TO OBTAIN WARRANTY SERVICE, Consumer must deliver the product prepaid, together with a detailed description of the problem, to:

New Providence Marine Systems

Attn: Warranty Service
PO Box 2272
Pocatello, ID 83206-2272

When requesting warranty service, purchaser must present a sales slip or other document which establishes proof of purchase. THE RETURN OF THE PRODUCT REGISTRATION FORM IS NOT A CONDITION PRECEDENT OF WARRANTY COVERAGE. However, please complete and return the Product Registration Form so that New Providence can contact you should a question of safety arise.

2. THIS WARRANTY DOES NOT COVER defects caused by modifications, alterations, repairs or service of this product by anyone other than New Providence; defects in materials or workmanship supplied by others in the process of installation of this product; defects caused by installation of this product other than in accordance with the manufacturer's recommended installation instructions or standard industry procedures; physical abuse to, or misuse of, this product. This warranty also does not cover damages to equipment caused by fire, flood, external water, excessive corrosion, or Act of God.

3. ANY EXPRESS WARRANTY NOT PROVIDED HEREIN, AND ANY REMEDY FOR BREACH OF CONTRACT WHICH BUT FOR THIS PROVISION MIGHT ARISE BY IMPLICATION OR OPERATION OF LAW, IS HEREBY EXCLUDED AND DISCLAIMED. ALL IMPLIED WARRANTIES SUCH AS THOSE OF MERCHANTABILITY AND OF FITNESS FOR A PARTICULAR PURPOSE, IF APPLICABLE, AS WELL AS ANY IMPLIED WARRANTIES WHICH MIGHT ARISE BY IMPLICATION OF LAW, ARE EXPRESSLY LIMITED TO A TERM OF ONE YEAR. SOME STATES DO NOT ALLOW LIMITATIONS ON HOW LONG A LIMITED WARRANTY LASTS, SO THE ABOVE LIMITATION MAY NOT APPLY TO YOU.

4. UNDER NO CIRCUMSTANCES SHALL NEW PROVIDENCE BE LIABLE TO PURCHASER OR ANY OTHER PERSONS FOR ANY SPECIAL OR CONSEQUENTIAL DAMAGES, WHETHER ARISING OUT OF BREACH OF WARRANTY, BREACH OF CONTRACT, OR OTHERWISE. SOME STATES DO NOT ALLOW THE EXCLUSION OR LIMITATION OF INCIDENTAL OR CONSEQUENTIAL DAMAGES, SO THE ABOVE LIMITATION OR EXCLUSION MAY NOT APPLY TO YOU.

5. No other person or entity is authorized to make any express warranty, promise or affirmation of fact or to assume any other liability on behalf of New Providence in connection with its products except as specifically set forth in this warranty.

6. This warranty gives you specific legal rights, and you may also have other rights which vary from state to state.

7: LIMITED WARRANTY

Product Registration Form

In order for us to notify you about possible safety issues or to notify you about possible product upgrades we request the following information. Having this dated form on file in our offices also serves to establish your purchase date for warranty issues.

Owner Information:

Name: _____.
Address 1: _____.
Address 2: _____.
City: _____ State: _____ ZIP: _____.
Phone: (____) _____ - _____.
Email: _____.

Product Information:

Product(s) Purchased: _____.
Date Purchased (MM/DD/YY): ___/___/___.
Where Purchased From: _____.
Make/Model of Boat: _____.
of Tanks Monitored: _____.

Please fill out as clearly as possible and return to:

New Providence Marine Systems

Attn: Product Registration
PO Box 2272
Pocatello, ID 83206-2272

8:PRODUCT REGISTRATION